

New !

ACO Drain® Multislot 150

Low comb channel
monolithic

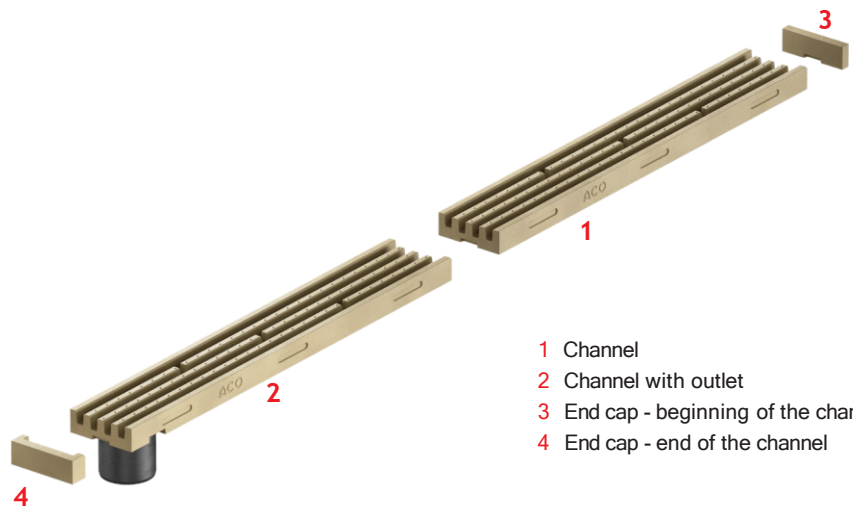
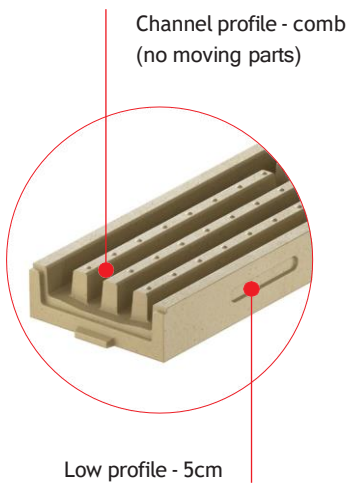

- 1 Channel
- 2 Channel with outlet
- 3 End cap - beginning of the channel
- 4 End cap - end of the channel

Typical applications

- Underground car garages
- Underground multi-level car parks for cars

Product benefits:

- Polymer concrete system, easy to seal
- Corrosion resistant system
- Fast and easy assembly
- No moving parts that can cause noise
- ACO DRAIN® Multislot is available in three colours (natural, gray, anthracite)
- Recommended solution for concrete and asphalt surfaces

ACO Drain®Multislot 150

Product information:

- Maximum load class: C 250
- Channel material: polymer concrete
- Channel profile - comb
- Channel type: no slope
- Edges: Polymer concrete

Product	Dimensions					PU	lthem num. natural	lthem num. grey	lthem num. anthracite
	Lenght	Width	Height	Weight					
	mm	mm	mm	kg	pcs./pallet				
ACO Multislot channel	1000	150	50	12,46	16	135213	135217	135221	
ACO Multislot channel with outlet	1000	150	50	12,27	4	135214	135218	135222	
ACO Multislot end cap beginning of the channel	1000	150	50	0,33	20	135215	135219	135223	
ACO Multislot end cap end of the channel	1000	150	50	0,51	20	135216	135220	135224	



Channel 1m natural



Channel 1m with outlet natural



End cap beginning of the channel natural



End cap end of the channel natural



Channel 1m grey



Channel 1m with outlet grey



End cap beginning of the channel grey



End cap end of the channel grey



Channel 1m anthracite



Channel 1m with outlet anthracite

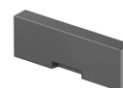

End cap beginning of the channel anthracite

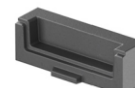

End cap end of the channel anthracite